

EIGERFLEX®

Cold water pipe



Cold water and sewage pipe

EIGERFLEX® – highly cost-effective

Ideal for extreme conditions

EIGERFLEX® pipes can be used wherever it is impossible to lay normal cold water pipes at sufficient depth to ensure protection against frost.

EIGERFLEX® pipes will even function perfectly under extremely cold and frosty conditions in northern regions or in mountainous areas.

The system is used as

- cold water piping for coastal and natural conservation areas and residential construction zones
- sewage piping for industrial and household applications

Freezing up? Impossible!

The self-adjusting frost protection strip makes it impossible for EIGERFLEX® pipes to freeze up.

The lambda value for PUR foam is 25 % better than for PE foam, so you can reduce your heat loss levels accordingly.

Best quality at optimal conditions

Thanks to the PE-100 inner pipe, EIGERFLEX® pipes offer a solution that is reasonably priced.

Normal commercial connection technology

Provision is made for house connections and joints to onward pipes. The EIGERFLEX® range includes all the screwed joints that you need.

Type	DN	Inches	Carrier pipe PE-100 ø mm	Protective sheathing ø mm	Min.radius when bent m	Volumen carrier pipe l/m	Weight kg/m	Max. length (coil)	
								Jumbo m	Maxi m
25/76	20	¾"	25 x 2,3	78	0,7	0,327	0,90	520	760
32/76	25	1"	32 x 2,9	78	0,7	0,539	1,00	520	760
40/91	32	1¼"	40 x 3,7	93	0,8	0,835	1,39	377	560
50/91	40	1½"	50 x 4,6	93	0,8	1,307	1,54	377	560
63/126	50	2"	63 x 5,8	128	1,0	2,091	2,60	192	280
75/126	65	2½"	75 x 6,8	128	1,0	2,961	2,75	192	280
90/162	80	3"	90 x 8,2	163	1,2	4,254	4,56	92	144
110/162	100	4"	110 x 10,0	163	1,2	6,362	5,69	92	144

Coil dimensions: Jumbo-Coil Ø outer diameter 2800 x 800 mm (width)

Maxi-Coil Ø outer diameter 2800 x 1200 mm (width)

> other categories of insulation thickness on request

As an alternative, it is possible to use the electric welding sleeves available through trade outlets.

narrow trenches. There is no need to brace the trenches.

Operating temperature: up to 30 °C

Operating pressure: up to 16 bar

Minimise underground construction costs

You will drastically reduce the costs of installing pipework, because EIGERFLEX® pipes only require

Adaptable to every terrain

The pipe routing is determined solely by the terrain conditions – reducing the length of pipe that needs to be laid to the absolute minimum.

The reason? EIGERFLEX® is so flexible that it can adapt to every type of terrain.

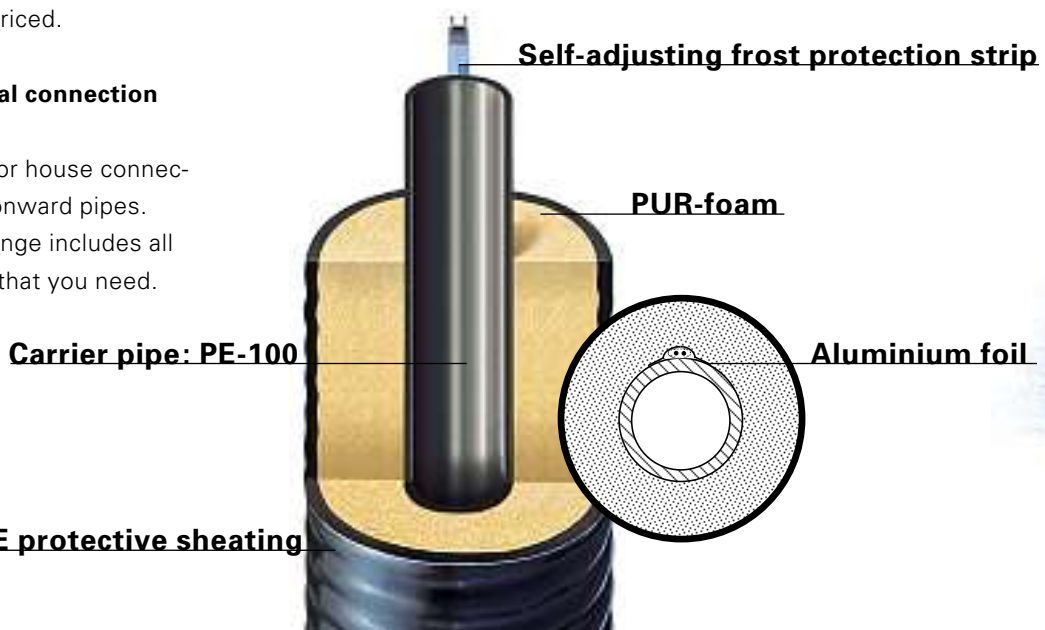

ing

ective, highly convincing



Installation sample

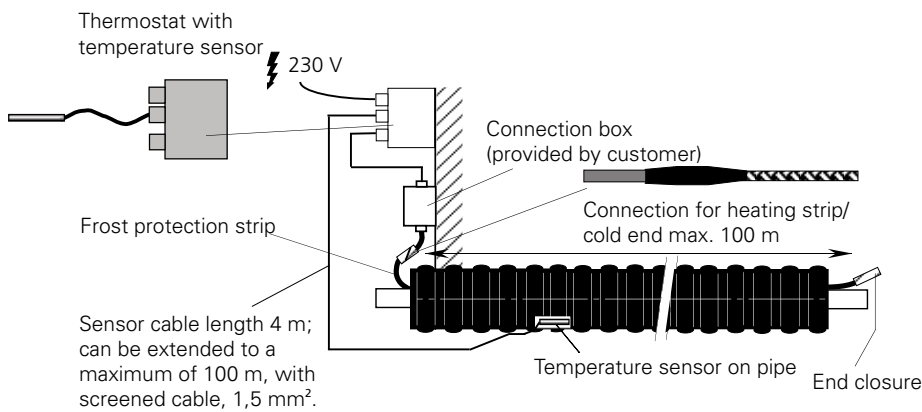

Depending on the internal temperature of EIGERFLEX®, the maximum length of the frost protection strip (without any additional power supply) is 50 to 100 m.

Please note the precise information given in the planning and pipe-laying instructions.

The frost protection strip is small – but highly effective!

The frost protection strip has a mains voltage of 230 V AC. Heat is continuously emitted at every point on the pipe, in relation to the ambient temperature – so there is no need for any additional adjustments.

To maximise savings on energy costs, we recommend to control the frost protection strip by a thermostat.

Prefabricated electrotechnics

All the components related to the frost protection strip – such as thermostats, T-pieces, joints with the cold end, including sealing fittings – are available in ready pre-fabricated form.



Pipe system for the future

District heating – Industry – Petrol stations – System packages



Your partner for pipe systems

We are the people you should talk to when you need to find efficient solutions for transporting liquid materials. With our project engineers, development department, in-house production unit and our professional team of fitters, we have the know-how and the resources to look after your projects competently and reliably. For all types of heating systems, petrol station construction, industrial plant construction and system packages.

International network

Our global partnership network can be reached on site at any time. More than 34 partners in 20 different countries will look after you wherever you are.

Customer-specific solutions

Brugg is the full service provider in the field of single-wall, double-wall and insulated pipe systems. This know-how allows us to manufacture project-specific customised items.

Give us a call!

Our engineers would be pleased to advise you and find a made-to-measure solution.

Brugg Rohrsystem AG

Industriestrasse 39
CH-5314 Kleindöttingen
phone +41 (0)56 268 78 78
fax +41 (0)56 268 78 79
pipesystems@brugg.com
www.pipesystems.com

BRUGG Rohrsysteme GmbH

Adolf-Oesterheld-Straße 31
D-31515 Wunstorf
phone +49 (0)50 31 170-0
fax +49 (0)50 31 170-170
info@brugg.de
www.brugg.de

A company of the BRUGG Group